

The Revolutionary series

MEMDOS LB - motor-driven diaphragm dosing pumps 4 – 1,020 l/h, up to 16 bar



Reliable dosing of chemicals

The motor-drive diaphragm dosing pump MEMDOS LB stands for robust quality and reliable dosing results. A selection of different motors for explosive risk zones rounds off the range.

The performance ranges from 0 – 4 up to 0 – 156 l/h for the first size, and 0 – 114 up to 0 – 1,020 l/h for the second size. The maximum permitted pressure, depending on the size, is between 3 and 16 bar.

Thanks to the sturdy tappet drive with manual or automatic capacity adjustment, the conveyed media such as acids, lyes, coagulants and flocculants are dosed reliably and precisely.

On request, the MEMDOS LB pumps can also be supplied with a double-diaphragm system. Then uncontrolled leakage of media is avoided even if the dosing diaphragm wears out.

Versatile and flexible

The MEMDOS LB is used when the integration of the pump into controls or control circuits is required.

For constant dosing without a controller, the motor of MEMDOS LB is directly connected to the terminal box. A great variety of three-phase and single-phase motors is available for this purpose.

To adapt the dosing capacity, either the stroke length can be adjusted mechanically or the speed of the three-phase motor can be regulated by means of a separate frequency converter.

Functions

- Output range from 4 – 1,020 l/h, up to 16 bar
- Power supply 115 V, 230 V or 400 V
- Material finishes PVC, PP, PVDF and stainless steel
- Infinitely variable stroke frequency from 0 – 100 %
- A variety of three-phase and alternating current motors
- ATEX versions are available for Zones 1 and 2
- Also suitable for frequency converter operation
- Double-diaphragm system (optional)
- Automatic stroke length adjustment (optional)

Technical specifications

MEMDOS LB			4	4-HP	10	10-HP	20	20-HP	35	60	80	150
Delivery capacity at max. back pressure	50 Hz	l/h	4	8.4	14	24	22	36		63	90	156
	60 Hz		4.8	10.1	16.8	28.8	26.4	43.2		75.6	108	187.2
Max. delivery pressure		bar	12	16	12	16	12	16	10		5	
Nominal stroke frequency	50 Hz	RPM	26		72		120		72	120	72	120
	60 Hz		31.2		86.4		144		86.4	144	86.4	144
Suction lift for non-gassing media		mWS	9						8		7	
Max. supply pressure		mbar	500									
Diameter of diaphragm		mm	52						64		90	
Valve size			DN4						DN6		DN10	
Voltage supply			230 / 400 V (optional 115 V)									
Protection class			IP55									
Insulation class			F									
Material			PP, PVC, PVDF, 1.4571									
Weight*	PP	kg	~ 8						~ 9.5		~ 9.5	
	PVC		~ 8						~ 9.5		~ 9.5	
	PVDF		~ 8						~ 9.5		~ 9.5	
	Stainless steel (1.4571)		~ 9.5						~ 15.5		~ 15.5	
Permitted ambient temperature		°C	5 – 45 (with PVC parts 5 – 40)									
Permitted media temperature		°C	80 (with PVC parts, 35; with PP parts 60)									

MEMDOS LB			110	160	210	260	310	400	510	760	1010	
Delivery capacity at max. back pressure	50 Hz	l/h	114	144	210	264	294	390	504	744	1020	
	60 Hz		136.8	172.8	252	316.8	352.8	468	604.8	892.8	1224	
Max. delivery pressure		bar	10				8	6	4		3	
Nominal stroke frequency	50 Hz	RPM	96	120	96	120	96	120	53	76	107	
	60 Hz		115.2	144	115.2	144	115.2	144	63.6	91.2	128.4	
Suction lift for non-gassing media		mWS	7		6		4.5		1			
Max. supply pressure		mbar	500									
Diameter of diaphragm		mm	90		120		150		185			
Valve size			DN10		DN15				DN25			
Voltage supply			230 / 400 V (optional 115 V)									
Protection class			IP55									
Insulation class			F									
Material			PP, PVC, PVDF, 1.4571									
Weight*	PP	kg	~ 15		~ 16		~ 20		~ 23.5			
	PVC		~ 15		~ 16		~ 20		~ 23.5			
	PVDF		~ 15		~ 16		~ 20		~ 23.5			
	Stainless steel (1.4571)		~ 20		~ 23		~ 31		~ 45.5			
Permitted ambient temperature		°C	5 – 45 (with PVC parts 5 – 40)									
Permitted media temperature		°C	80 (with PVC parts, 35; with PP parts 60)									

*) Weights can vary slightly depending on the motors; these figures represent average values.

Delivery characteristic curves

These delivery capacities were determined on the manufacturer's test stands. They apply at 20 °C (68 °F) for water, at 100 % stroke frequency. The delivery capacity depends on the medium (density and viscosity) and temperature. Since these conditions vary at every installation location, you should calibrate the dosing pump.

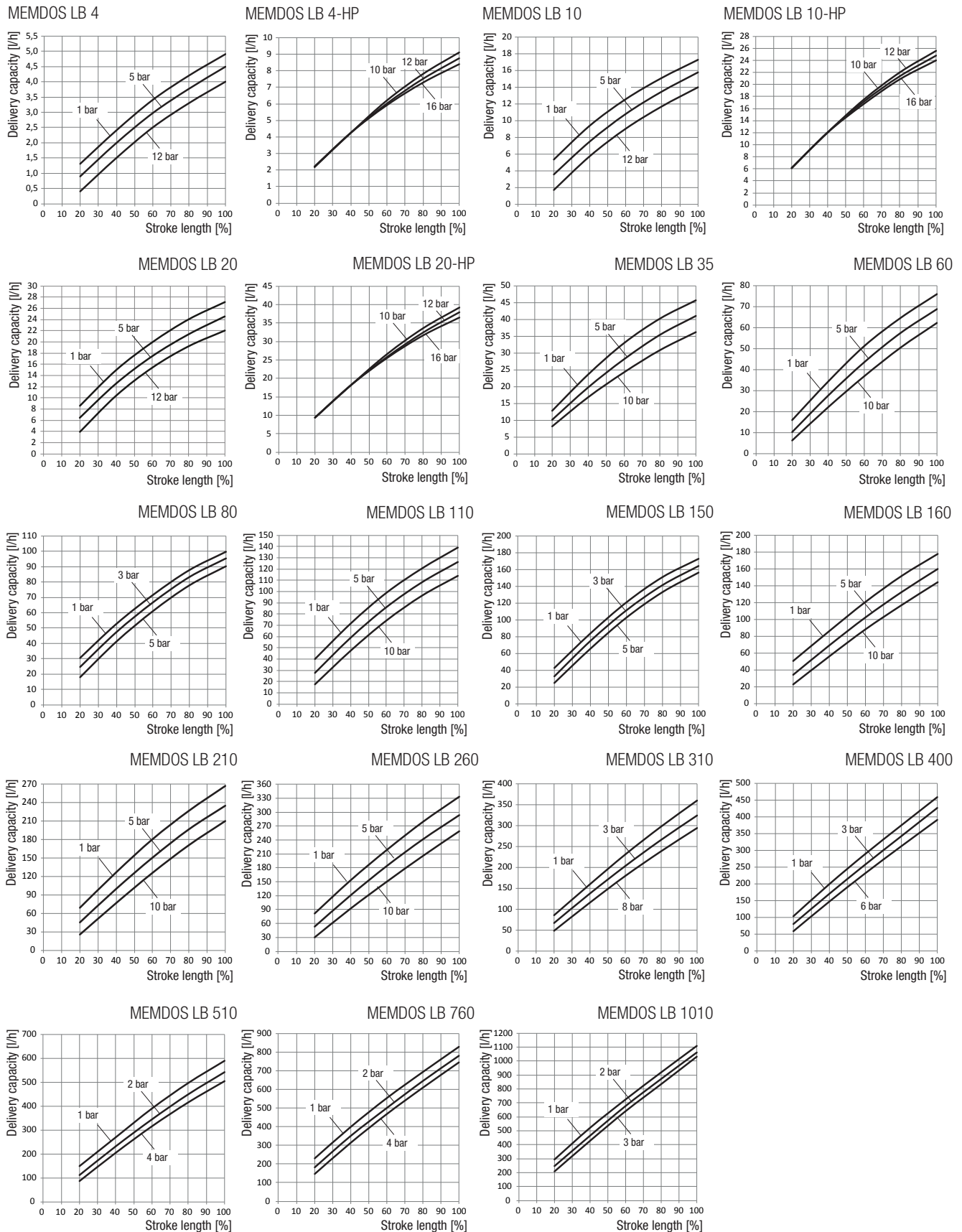

Dimensions

MEMDOS LB 4 – 80 and 150

All dimensions in mm

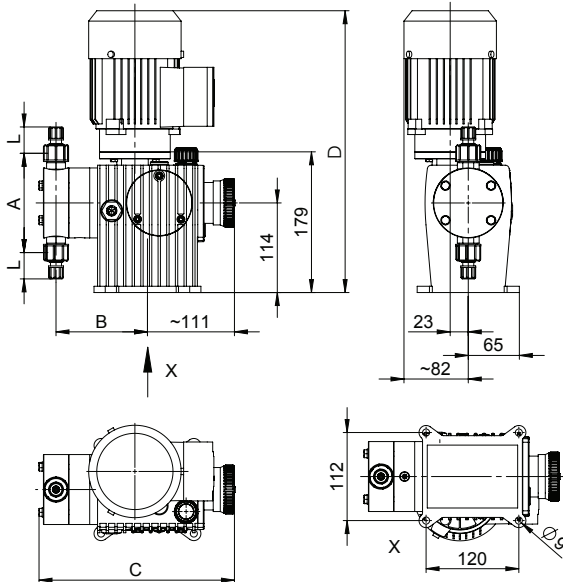

MEMDOS LB 110, 160 – 1010

All dimensions in mm

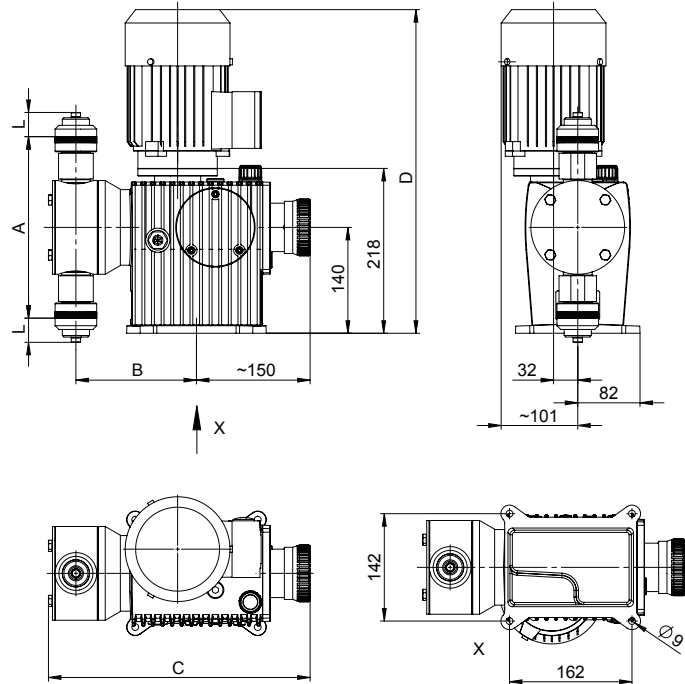

Scale	4 – 20	35 – 60	80, 150	110, 160	210 – 260	310 – 400	510 – 1010
A	126	149	249	249	268	312.5	352
B	116	121.5	133	160	170	175	208 (*194.3)
C	249	256	280	346	357	362	402 (*375.5)
D	389	389	389	437	437	437	450
L	Depends on the connection type and size						

*) Dosing head made of stainless steel

MEMDOS LB standard - accessories



Suction lines

Flexible suction line, SA model with foot valve and load part made from ceramic and 2,500 mm hose length.



Suction and pressure tube

Permissible operating pressure at 20 °C in accordance with DIN EN ISO 7751, chemical resistance and correct connection are assumed.

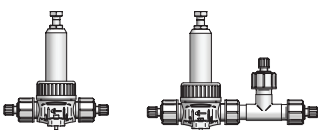

Back pressure and pressure relief valves

Back pressure valves to be mounted in the dosing line.
Adjustable pressure 1 – 16 bar

Pressure relief valves to be mounted in the dosing line.
Adjustable pressure: Plastic 1 – 16 bar, stainless steel 1 – 25 bar